



MANUFACTURER OF ROTARY DRUM GRANULATORS, DRYERS, COATERS, COOLERS, AND HEATERS

Whether your process requires drying, mixing, granulating, coating, heating, or cooling; rotary drum systems fabricated at Applied Chemical Technology (ACT) since 1981 offer efficient, economical solutions for your process production needs. Our combination of superior technology and economical pricing sets ACT rotary drums far above the competition. This is not surprising as many of today's most innovative rotary drum processes were developed by ACT's engineers. Our drums are in use throughout the international chemical products industry, processing everything from fertilizers to industrial plastics. Choose from our standard model or let us custom design your rotary drum to meet your needs and processing requirements.

Rotary Drums

Materials of Construction: Carbon Steel, Stainless Steel, and Specialty Alloys
Capacities: 50 lbs/hr to 200 tons/hr
Diameters: 1 foot to 14 foot diameter
Lengths: Up to 60 feet (single segment), Up to 150 feet (multiple segments)



Rotary Drum Process Applications

ACT ROTARY DRUMS ARE IDEAL FOR A WIDE RANGE OF APPLICATIONS, INCLUDING:

- | | | | |
|--------------------|---------|--------------|--------------|
| Granulating | Cooling | Conditioning | Impregnating |
| Agglomeration | Drying | Incinerating | Classifying |
| Chemical Reactions | Coating | Milling | Filtering |
| Spray Granulation | Heating | Mixing | |

Standard Rotary Drums

ACT provides a variety of rotary drum models suitable for any application. Many of our models include internals/flighting, heating and cooling units, or other built-in features to save you space and money. Sizes of our standard models range from counter-top laboratory rotary drums (capable of approximately 1 to 5 kg batches (depending on material) to pilot scale models producing up to 1 ton/hr. In addition, we fabricate commercial-scale rotary drums with operating capacities up to 100 tons/hr and more. We also build complete processing systems to handle every aspect of your production.

- | | | |
|--|---|--|
| <ul style="list-style-type: none"> Shell Thicknesses Up to 1 1/2" Carbon Steel or Stainless Steel Construction Drive System Built for Your Application and Preference <ul style="list-style-type: none"> Gear – High Horsepower Chain – Lower Horsepower Friction – Low Cost, Easily Adjustable Riding Ring "Floating Tire" <ul style="list-style-type: none"> High Heat Expansion Toleration Heat Treated for Hardness Reduces Operating Stresses Ring Design Eliminates Uneven Wear Trunnions and Thrust Rollers <ul style="list-style-type: none"> One Piece Forged Steel Construction Bearings Rated for Minimum 50,000 Hours 1045 or 4140 Heat Treated Carbon Steel Friction Trunnions are Rubber or Polyurethane Adjustable Alignment Speed Reducer/Motor <ul style="list-style-type: none"> Soft Starts Available Fluid Coupling Variable Speed (Mechanical/Electrical) Programmable Drives Speed Sensing Reverse Operation | <ul style="list-style-type: none"> Optional Internals <ul style="list-style-type: none"> Lifting Flights Mixing Flights Spiral Flights Anti-slip Flights Bed Shaping Flights Collection Pans Liquid/Solid/Slurry/Gas Distribution Systems Reciprocating Scraper Bars Spray Systems – air atomizing Heating/Cooling Systems We Provide On-site Precision Alignment for Every Drum We Sell Unitized Base or Two Tier Design Modular or Complete System Designs Easy Operation and Clean Up | |
|--|---|--|



Specialty Designs and Modifications



At Applied Chemical Technology (ACT) we understand that one size does not fit all. That is why our rotary drums are easily modified to suit your specific needs. Also, ACT can design and fabricate custom internals for your existing drum, allowing you to improve your process efficiency or even re-purpose your drum for a new process. Whatever the need, we can design and fabricate a rotary drum to achieve your objective.

Your Specialty Rotary Drum Could Include:

- Custom Drum Internals
- Screen Shell Sections for Material Sizing/Classifying
- Hoods or Breechings
 - Dust Seals
 - Access Doors
 - Customized for Your Process
- Steam Jacketing
- Shell Access Doors - Servicing of Drum Internals
- Flanged Shell
- Rubber Shell Liners - Prevent Material Build Up
- Shell Hammers - Knock Product Loose
- Variable Slope
- Bucket Discharge
- Slow Running/Fast Running Operation
- Unitized or Separate Trunnions and Drive Bases
- Skid Mounted Rotary Drum System
- Complete Rotary Drum Systems
 - Full Granulation Systems
 - Inert Atmosphere Systems
 - Blowers
 - Heaters
 - Complete Plants
- Multi-function Rotary Drum Design
 - Heating, Coating, Drying, Cooling, Screening, etc. in a Single Drum
 - Batch or Continuous Process
- Automated Controls
 - Motor Controls
 - Instrumentation
 - PLC/HMI
 - Control System Integration

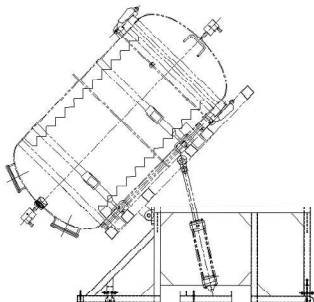
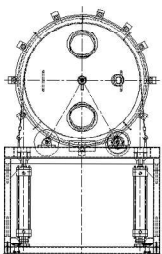

The stability of ACT's workforce provides continuity across longterm projects.

To find out more about our services or to discuss your project with an ACT engineer, you may contact Applied Chemical Technology by phone, mail, email, or web form. All initial consultations are strictly confidential and free of charge.

Why ACT?



Applied Chemical Technology, Inc.

4350 Helton Drive

Florence, Alabama, USA 35630

800-ACT-3217 • 256-760-9600

Fax: 256-760-9638

act@appliedchemical.com

website: appliedchemical.com



Visit us online appliedchemical.com